



THIS IS CONFIDENTIAL INFORMATION.
THIS DRAWING AND DESIGN IS THE PROPERTY OF LIQUIP INTERNATIONAL PTY LIMITED.
IT MUST NOT BE COPIED OR REPRODUCED IN ANY WAY WHATSOEVER AND/OR PASSED ON
TO ANY THIRD PARTY WITHOUT WRITTEN AUTHORITY.

LIQUIP INTERNATIONAL PTY LIMITED - ENGINEERING DEPARTMENT - 13 HUME RD SMITHFIELD SYDNEY NSW AUSTRALIA 2164
PH: +61 2 9725 9000 FAX: +61 2 9609 4739 EMAIL: engineering@liquip-nsw.com.au

Swivel Joint 32mm (1 1/4")

DATA SHEET

PART N°: SJ032

TITLE:	Swivel joint 32mm threaded mounting.
PURPOSE:	The swivel allows a trouble free rotation by utilisation of ball bearings, thus eliminating thrust & hose kinking. The swivel body is manufactured from lightweight aluminium, anodised for long life.
OPERATION:	The swivel incorporates a check valve, to retain residual pressure in the hose. (Mandatory under NSC regulations)
DISMANTLE:	Unscrew nut to remove poppet. Remove plug to release ball bearings and separate halves
ADJUSTMENT OR SERVICE:	None
MATERIALS OF CONSTRUCTION:	Anodised aluminium body Aluminium poppet Steel ball bearings Viton sealing o-ring
MOUNTING:	1 1/4" tapered male BSP thread 1 1/4" hose tail <u>NOTE:</u> Ensure sufficient flow area between poppet and bore of female body when assembled.
WEIGHT:	0.38 kg
TECHNICAL DATA:	Poppet opens at 55kPa
ASSOCIATED EQUIPMENT:	SJ1.5L 1 1/2" swivel with Male/female thread.

Overall dimensions shown on the drawing overleaf.



THIS IS CONFIDENTIAL INFORMATION.
 THIS DRAWING AND DESIGN IS THE PROPERTY OF LIQUIP INTERNATIONAL PTY LIMITED.
 IT MUST NOT BE COPIED OR REPRODUCED IN ANY WAY WHATSOEVER AND/OR PASSED ON
 TO ANY THIRD PARTY WITHOUT WRITTEN AUTHORITY.

LIQUIP INTERNATIONAL PTY LIMITED - ENGINEERING DEPARTMENT - 13 HUME RD SMITHFIELD SYDNEY NSW AUSTRALIA 2164
 PH: +61 2 9725 9000 FAX: +61 2 9609 4739 EMAIL: engineering@liquip-nsw.com.au

LIQUIP

SJ032 SWIVEL JOINT

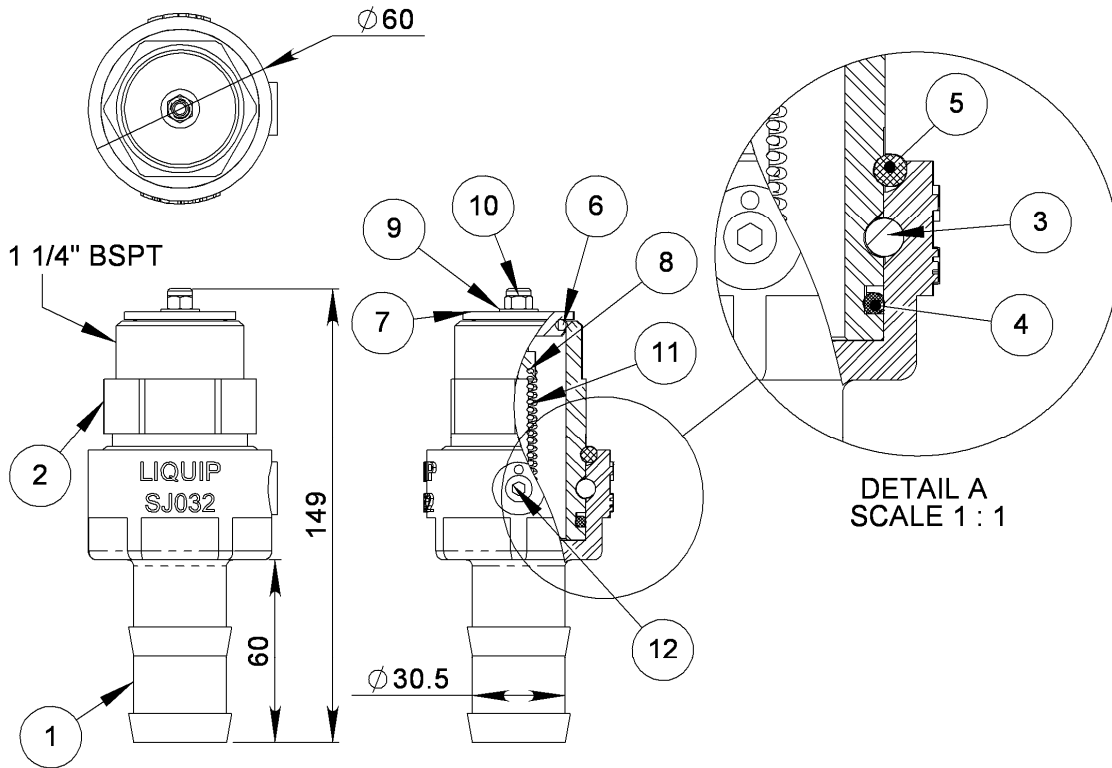

ITEM NO.	PART NUMBER	DESCRIPTION	QTY.	MATERIAL
1	SJ032-1	BODY OUTER HOSE TAIL	1	ALUMINIUM
2	SJ032-2	BODY INNER 1 1/4" MBSPT	1	ALUMINIUM
3	1031	BALL BEARING	22	ST STEEL
4	7535	O-RING	1	VITON A
5	0142	O-RING	1	NITRILE
6	0117	O-RING	1	VITON A
7	SJ1.25-3	POPPET	1	ALUMINIUM
8	SJ1.25-4	SPINDLE	1	STEEL
9	0099	WASHER FLAT	1	STEEL
10	0153	NUT NYLOC	1	Z/P STEEL
11	6113	SPRING COMPRESSION	1	SPRING STEEL
12	3246	PLUG TAPERED	1	BRASS

X1100004

Issue: B

METERS - VALVES - VENTS - MANHOLES - PUMPS - HOSEREELS - OVERFILL PROTECTION - LOADING ARMS - ELECTRONIC DIPSTICKS



LIQUIP INTERNATIONAL PTY LTD
 13 Hume Road
 Smithfield, 2164
 Sydney NSW Australia
 Phone: +612 9725 9000
 Fax: +612 9725 1252

DISTRIBUTORS
 See inside front cover
 for Liquip branches
 and Distributors

www.liquip.com