



THIS IS CONFIDENTIAL INFORMATION.
THIS DRAWING AND DESIGN IS THE PROPERTY OF LIQUIP INTERNATIONAL PTY LIMITED.
IT MUST NOT BE COPIED OR REPRODUCED IN ANY WAY WHATSOEVER AND/OR PASSED
ON TO ANY THIRD PARTY WITHOUT WRITTEN AUTHORITY.

LIQUIP INTERNATIONAL PTY LIMITED - ENGINEERING DEPARTMENT - 13 HUME RD SMITHFIELD SYDNEY NSW AUSTRALIA 2164
PH: +61 2 9725 9000 FAX: +61 2 9609 4739 EMAIL: engineering@liquip-nsw.com.au

AIR OPERATED VAPOUR VENT

P7295

DATA SHEET

PART No: AVV075VW

- TITLE:** A light and simple, air operated vapour vent with 90mm nominal diameter outlet and Sequential air actuation.
- OPERATION:** To allow venting of vapour from tank compartments while loading or unloading. Operated by a piston, the poppet opens inwards to prevent leakage from product surge.
- FEATURES:** The sequencing valve is offered to ensure main poppet is fully open before next vent opens. The end signal can then be used to provide a permissive signal for loading/unloading in the certainty that all vapour vent poppets are open. The sequencing valve can be blanked if not required.
- DISMANTLE:** Not recommended
- ADJUSTMENT:** None required
- MOUNTING:** Mounts directly on to tapped weld flanges in aluminium, steel or stainless steel for walkway and coaming mount. Bolted from above through body.
- TECHNICAL DATA:** Operating pressure 120kPa to 900kPa (normal 500kPa)
Consumption/stroke 1 litre free air.
Aluminium body
Acetal piston and viton seals.
Weight: 1.9 kg
- ASSOCIATED EQUIPMENT:** VRB3.5-1 & 2 - Weld stub to allow venting into coaming (aluminium & mild steel)
Mounting flanges in aluminium, mild steel & stainless (variations shown below)
AVV3-12 - Polyurethane louvre for weather & anti-spark protection
AVV075V with blind inserts for mounting.
AVV075VVG with Viton GFLT seals for use with ethanol
AVV075K with Kalrez seals
Spark Arresting Gauze (optional).
Stainless steel version available, AVV3SST

Overall dimensions shown on the drawing overleaf.



THIS IS CONFIDENTIAL INFORMATION.
 THIS DRAWING AND DESIGN IS THE PROPERTY OF LIQUIP INTERNATIONAL PTY LIMITED.
 IT MUST NOT BE COPIED OR REPRODUCED IN ANY WAY WHATSOEVER AND/OR PASSED
 ON TO ANY THIRD PARTY WITHOUT WRITTEN AUTHORITY.

LIQUIP INTERNATIONAL PTY LIMITED - ENGINEERING DEPARTMENT - 13 HUME RD SMITHFIELD SYDNEY NSW AUSTRALIA 2164
 PH: +61 2 9725 9000 FAX: +61 2 9609 4739 EMAIL: engineering@liquip-nsw.com.au

LIQUIP

AVV075VW VAPOUR VENT

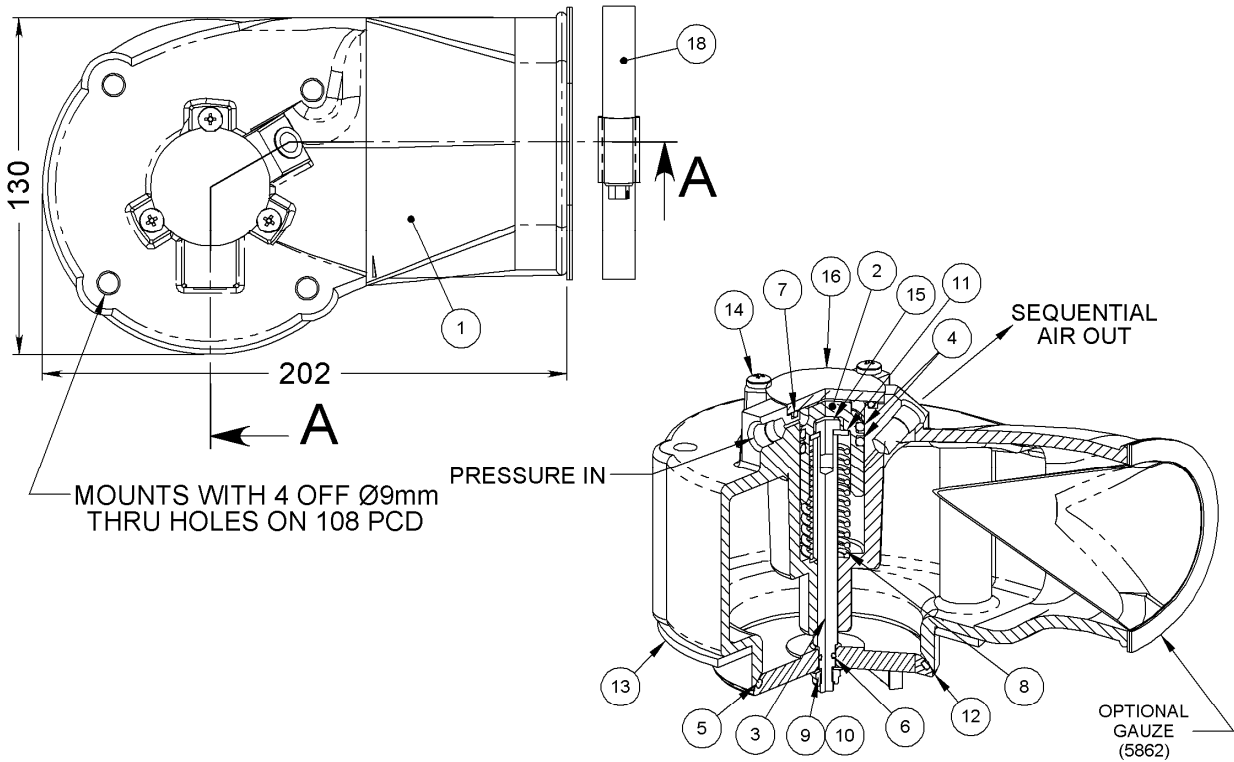

ITEM NO.	PART NUMBER	DESCRIPTION	AVV075VW	MATERIAL
1	AVV075W-1	BODY FOR LOW PROFILE	1	ALUMINIUM
2	AVV075V-3	PISTON	1	ACETAL
3	AVV075V-6	SHAFT - LOW PROFILE	1	ST STEEL
4	4574	O-RING	2	VITON
5	4507	O-RING	1	VITON
6	6088	O-RING	1	VITON
7	6089	O-RING	1	NITRILE
8	6141	SPRING COMPRESSION	1	ST STEEL
9	4400	NUT HALF NYLOC	1	STEEL
10	5267	WASHER FLAT	1	STEEL
11	5329	WASHER FLAT	1	STEEL
12	AVV075V-4	POPPET	1	ALUMINIUM
13	3096	GASKET FOR AVV's	1	NEOCORK
14	6501	SCREW METRIC	3	ST STEEL
15	6523	SETScrew MET	1	STEEL
16	AVV075V-5	LID FOR LOW PROFILE VAPOUR VENT	1	ALUMINIUM
17	7295	INSTRUCTION LEAFLET	1	PAPER
18	2308	CLAMP HOSE No.5	2	STEEL

X200102

Issue: I

METERS - VALVES - VENTS - MANHOLES - PUMPS - HOSEREELS - OVERFILL PROTECTION - LOADING ARMS - ELECTRONIC DIPSTICKS



LIQUIP INTERNATIONAL PTY LTD
 13 Hume Road
 Smithfield, 2164
 Sydney NSW Australia
 Phone: +612 9725 9000
 Fax: +612 9725 1252

DISTRIBUTORS
 See inside front cover
 for Liquip branches
 and Distributors

www.liquip.com

MOUNTING OF AVV075 SERIES VAPOUR VENTS

MOUNTING TO COAMINGS

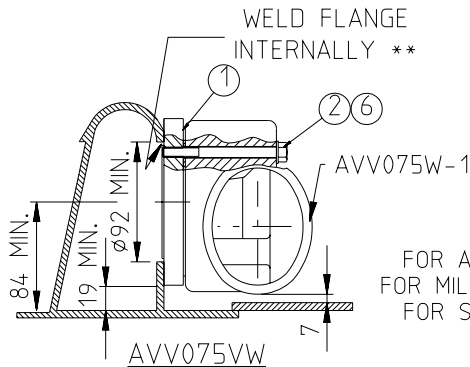

- NOTES:
 1. THIS SYSTEM WAS DESIGNED ONLY FOR VAPOUR RECOVERY VALVES MOUNTED INTO ROLL-OVER COAMING. USE ONE OF THE OTHER SYSTEMS FOR COMPARTMENT MOUNTING.
 2. THREAD SEALANT IS REQUIRED FOR THROUGH HOLE FLANGES.
 3. ** ENSURE POPPET CLEARS WELD!

FOR ALUMINIUM COAMINGS, USE ALUMINIUM FLANGE AVV3L-9
 FOR MILD STEEL COAMINGS, USE MILD STEEL FLANGE AVV3L-10
 FOR ST STEEL COAMINGS, USE ST STEEL FLANGE AVV3.0-9

MOUNTING TO WALKWAYS

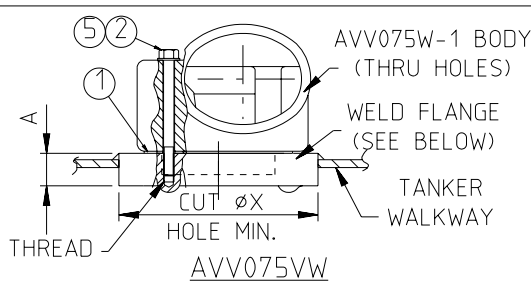

WELD FLANGES WITH TAPPED HOLES

PART	MAT'L	THREAD	CUT ØX	DIM 'A'
AVV3U-7	ALUM	8mm METRIC	153	25
AVV3U-8	STEEL	8mm METRIC	153	25

MOUNTING TO MANHOLES

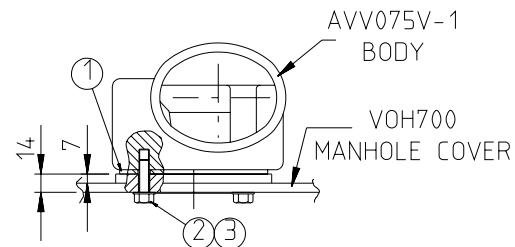
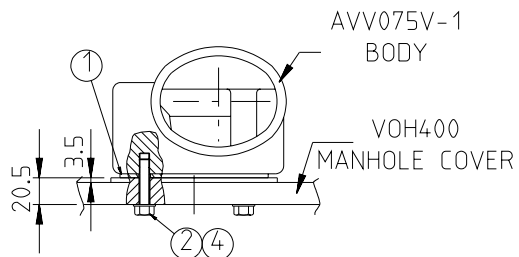
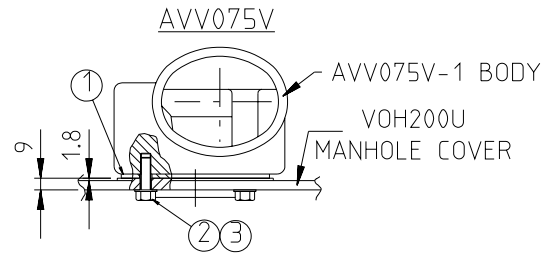

- NOTES:
 1- FOR CHEMICAL APPLICATIONS USE STAINLESS STEEL EQUIVALENTS FOR FASTENERS AND EXPANDED PTFE FOR GASKET.

ITEM	PART NO	DESCRIPTION	QTY	MATERIAL
1	3096	GASKET	1	NEOCORK
2	4943	WASHER SPRING 8mm	4	Z/P STEEL
3		SETSCREW M8 x 25 LONG HEX HEAD	4	Z/P STEEL
4		SETSCREW M8 x 35 LONG HEX HEAD	4	Z/P STEEL
5		BOLT M8 x 90 LONG HEX HEAD	4	Z/P STEEL
6	4880	BOLT 5/16" BSW X 3 1/2" LONG HEX HEAD	4	Z/P STEEL

P7294

Issue: D